

High Precision Milling Tool for Spot Welding Electrodes as per DIN/ISO 5821

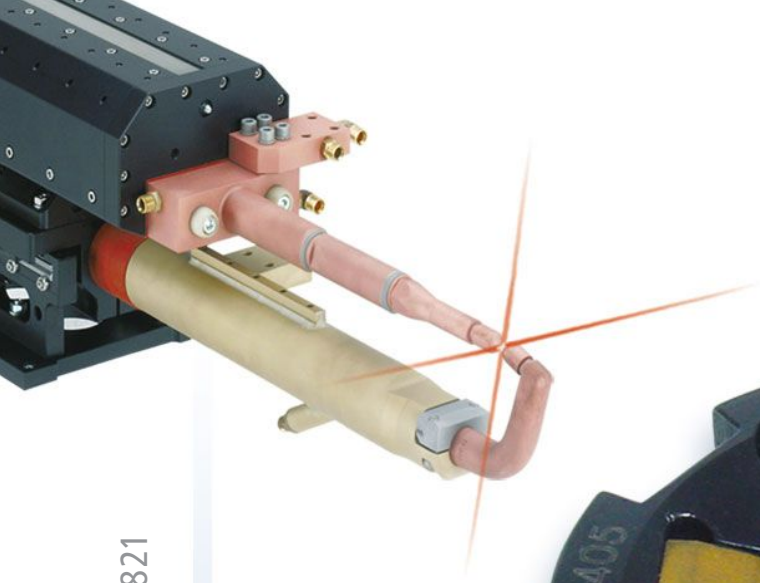

Single-Blade milling tool



- For electrode caps
French standard or similar
- Interchangeable cutter blade
- HSS cutter blade,
titanium coated
- Castellated tool holder with
circlip retention

Lutz Technik GmbH

Hildachstrasse 12-14
D - 81245 München

Phone: +49 (0)89 820 306 -0
Fax: +49 (0)89 820 306 -59
www.lutz-precision.com

Lutz Técnica Brasil Ltda.

Rua Irineu Vilella Veiga, 135
Salas 06 e 07, CEP 89.279-000
Bairro Centro - Guaramirim, SC - Brasil

Phone: +55 47 373 - 2659
Fax: +55 47 373 - 3527

Lutz Precision Ltd.

368 Betty Street
Windsor, ON N8S 3W6,
Canada

Phone: +1 519 566 92 16
Fax: +1 866 362 59 88

Dressing tools are available for the following ISO standard electrodes and in conversion holders to fit in these competeters machines:* ABB, AEG, AMDP, Bräuer, EDI, Exrod, Gem, Hitech, Obara, Retek, Rotech, Sementorq, Sinterleghe, Stillwater.

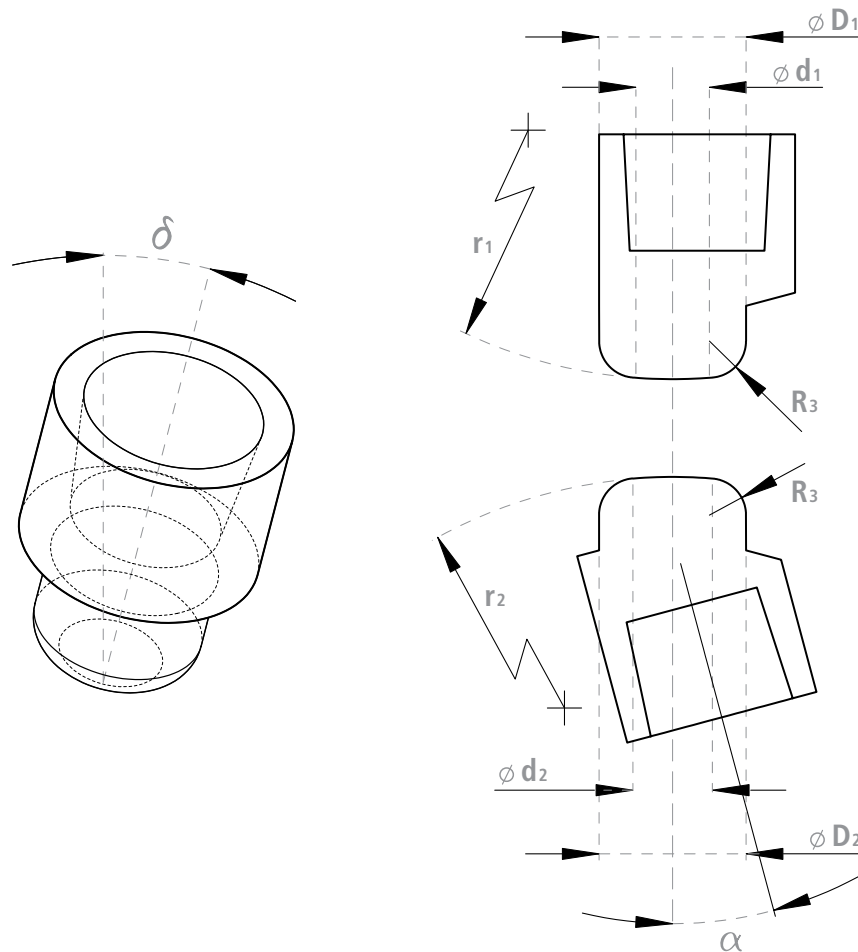
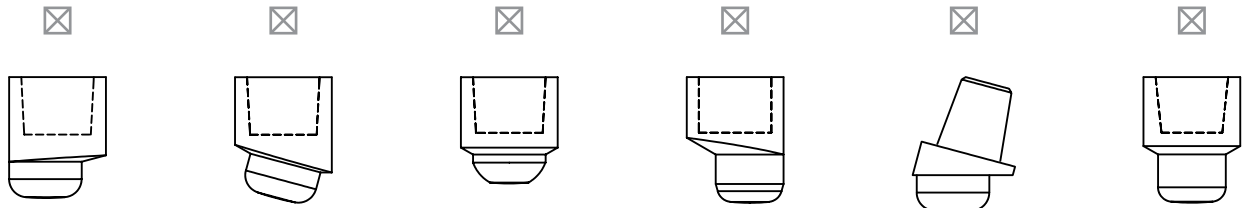

Part number	Lutz reference	d ₁	D ₁	r ₁	d ₂	D ₂	r ₂	α	δ	Holder
GY8,0/4-8,0/4-R3-F	3.87.00.04	8,0	14,0	40	8,0	14,0	40	5°,10°,15°,18°, 20°	0°-15°	F
GY6,0/4-6,0/4-R3-F	3.87.00.05	6,0	12,0	40	6,0	12,0	40	5°,10°,15°,18°, 20°	0°-15°	F

* Specials available upon request. Variations in cap profile can occur depending on weld gun geometry and correct alignment.

High Precision Milling Tool for Spot Welding Electrodes as per DIN/ISO 5821