

High Precision Milling Tool for Spot Welding Electrodes as per DIN/ISO 5821

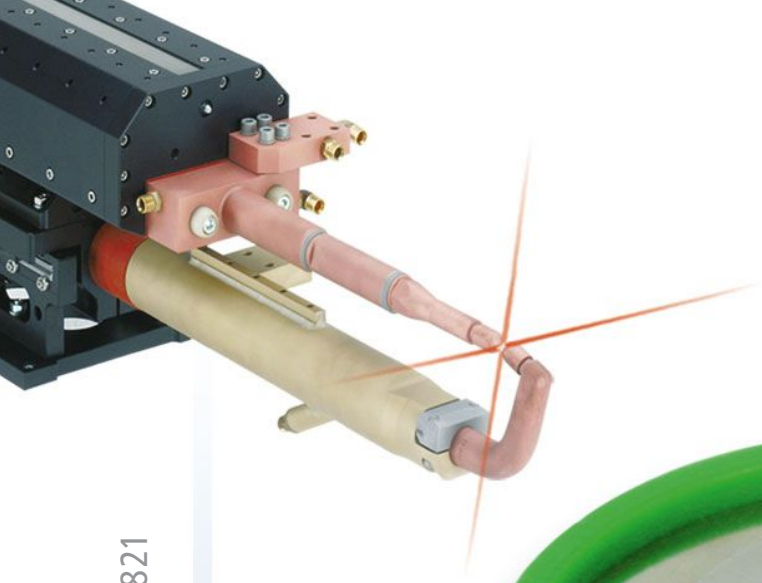

Single-Blade milling tool



- For electrode cap form E, G (ISO 5821) or similar
- Interchangeable cutter blade
- HSS cutter blade, titanium coated
- Bayonet tool holder
- Colour coding ring
- Integrated cutter rotation detection (3LED)

Lutz Technik GmbH

Hildachstrasse 12-14
D - 81245 München

Phone: +49 (0)89 820 306 -0
Fax: +49 (0)89 820 306 -59
www.lutz-precision.com

Lutz Técnica Brasil Ltda.

Rua Irineu Vilella Veiga, 135
Salas 06 e 07, CEP 89.279-000
Bairro Centro - Guaramirim, SC - Brasil

Phone: +55 47 373 - 2659
Fax: +55 47 373 - 3527

Lutz Precision Ltd.

368 Betty Street
Windsor, ON N8S 3W6,
Canada

Phone: +1 519 566 92 16
Fax: +1 866 362 59 88

Dressing tools are available for the following ISO standard electrodes and in conversion holders to fit in these competitors machines: * **ABB, AEG, AMDP, Bräuer, EDI, Exrod, Gem, Hitech, Obara, Retek, Rotech, Semtorq, Sinterleghe, Stillwater.**

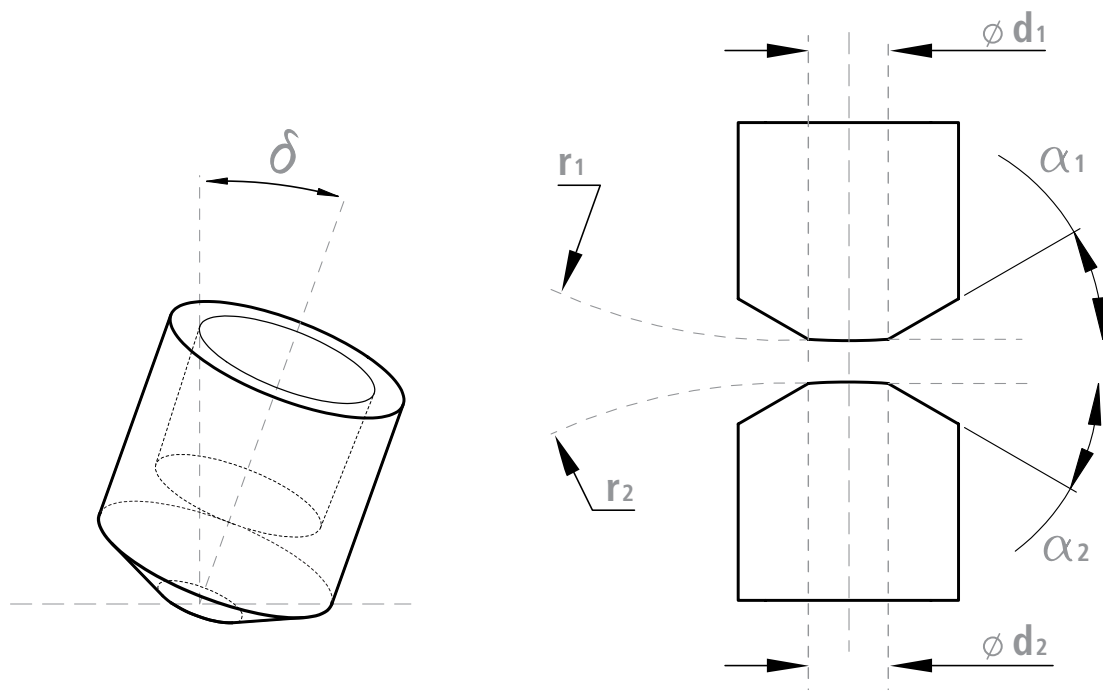
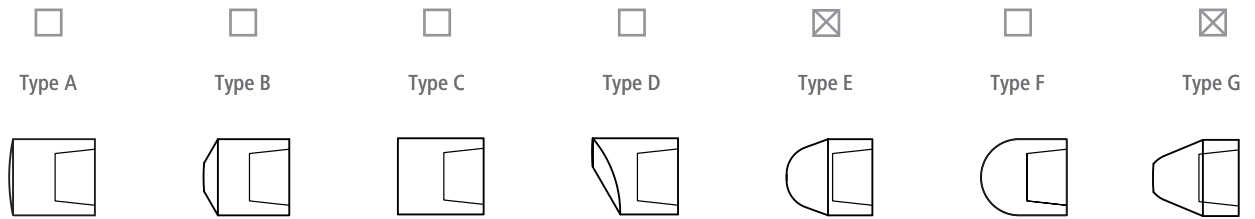

Part number	Lutz reference	d ₁	r ₁	α ₁	d ₂	r ₂	α ₂	Holder	δ
GY5,8/4-5,8/4-55-2	3.88.00.90	5,8	40	55	5,8	40	55	Lutz 2	0°-15°
GY6,0/4-6,0/4-55-2	3.88.00.58	6,0	40	55	6,0	40	55	Lutz 2	0°-15°
GY6,3/4-6,3/4-55-2	3.89.00.08	6,3	40	55	6,3	40	55	Lutz 2	0°-15°
GY8,0/4-8,0/4-50-A	3.88.00.09	8,0	40	50	8,0	40	50	AEG	0°-15°

* Specials available upon request. Variations in cap profile can occur depending on weld gun geometry and correct alignment.